

Locating pins and rest pads DIN 6321

Item description/product images

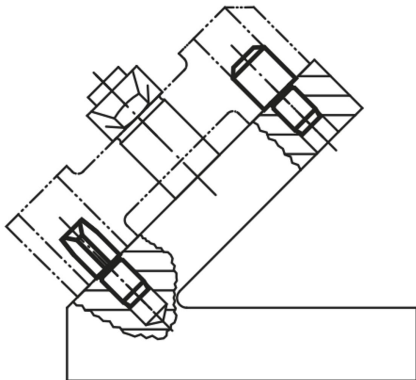
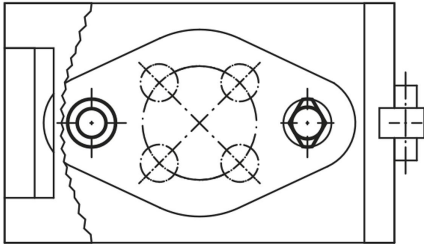

Description

Material:
Tool steel.

Version:
Hardened and ground.

Note:

Rest pads Form A are supports for workpieces and fixtures.

Locating pins Form B are for positioning workpieces and fixture components in reamed holes.

The flattened Form C can be used to bridge tolerances in hole spacing or to secure the part to be positioned in one direction only.

Form A and B can also be used as hardened stops and as fixture feet.

For similar pins see B0177 and B0178.

Drawing reference:

Form A: Rest pad

Form B: Cylindrical locating pin

Form C: Flattened locating pin

For other dimensions see Form A.

Locating pins and rest pads DIN 6321

Drawings

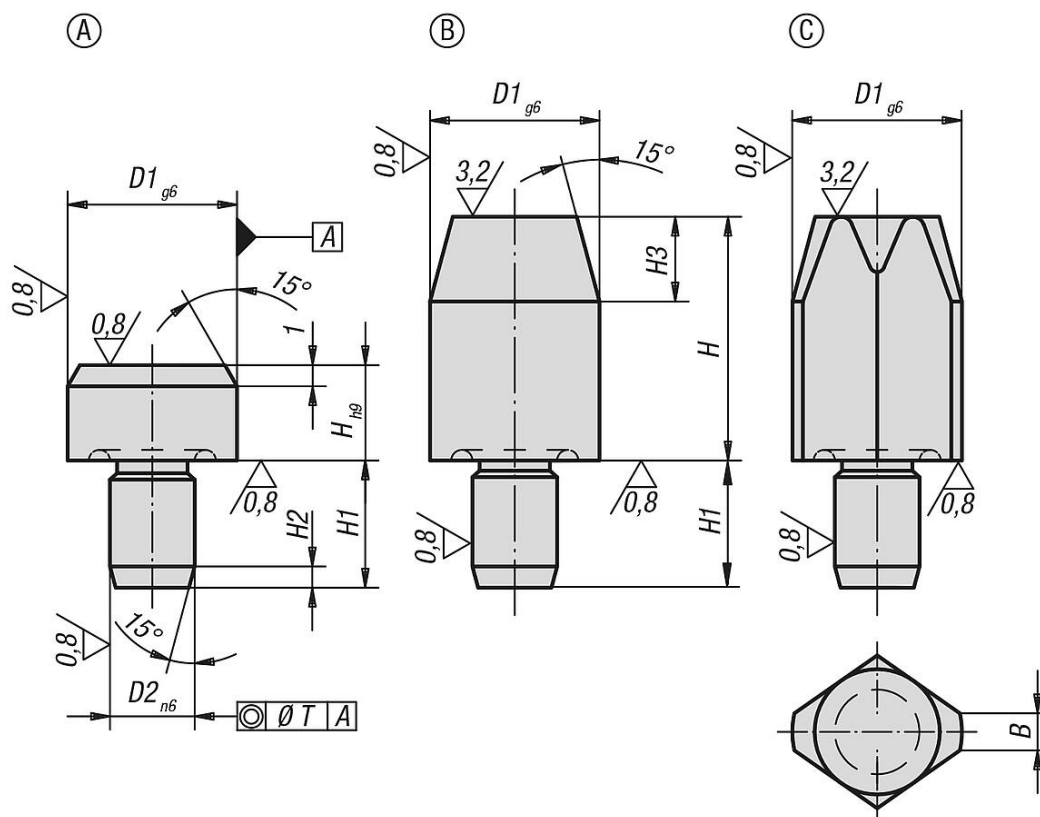

Overview of items

Rest pads, Form A

Order No. without centre bore	D1	D2	H	H1	H2	T
B0180.106	6	4	5	6	1,2	0,02
B0180.110	10	6	6	9	1,6	0,02
B0180.116	16	8	8	12	2	0,04
B0180.125	25	12	10	18	2,5	0,04

Locating pin cylindrical, Form B

Order No. short	Order No. long	D1	D2	H	H1	H2	H3	T
B0180.206	B0180.306	6	4	7/12	6	1,2	4	0,02
B0180.208	B0180.308	8	6	10/16	9	1,6	6	0,02
B0180.210	B0180.310	10	6	10/18	9	1,6	6	0,02
B0180.212	B0180.312	12	6	10/18	9	1,6	6	0,02
B0180.216	B0180.316	16	8	13/22	12	2	8	0,04
B0180.220	B0180.320	20	12	15/25	18	2	9	0,04
B0180.225	B0180.325	25	12	15/25	18	2,5	9	0,04

Locating pin rhombic, Form C

Order No. short	Order No. long	B	D1	D2	H	H1	H2	H3	T
B0180.406	B0180.506	1	6	4	7/12	6	1,2	4	0,02
B0180.408	B0180.508	1,6	8	6	10/16	9	1,6	6	0,02

Locating pins and rest pads DIN 6321

Overview of items

Order No. short	Order No. long	B	D1	D2	H	H1	H2	H3	T
B0180.410	B0180.510	2,5	10	6	10/18	9	1,6	6	0,02
B0180.412	B0180.512	2,5	12	6	10/18	9	1,6	6	0,02
B0180.416	B0180.516	3,5	16	8	13/22	12	2	8	0,04
B0180.420	B0180.520	5	20	12	15/25	18	2	9	0,04
B0180.425	B0180.525	5	25	12	15/25	18	2,5	9	0,04