

Fixture feet with internal thread

Item description/product images

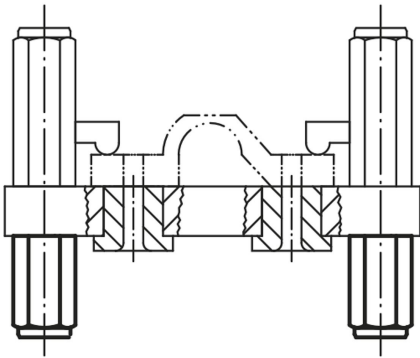
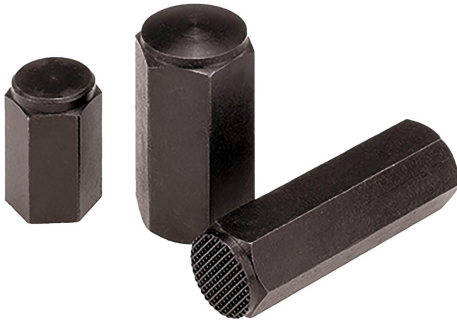

Description

Material:

Body high carbon steel.

Version:

Body tempered and black oxidised.

Contact faces case-hardened.

Note:

Fixture feet with internal thread are used as supports for fixtures or rough or machined workpieces. They can also be used as stops or thrust pads in fixtures and toolmaking.

Drawing reference:

Form A: hardened face

Form B: face hardened and ground

Form C: hardened spherical surface

Form D: tempered serrated surface

Fixture feet with internal thread

Drawings

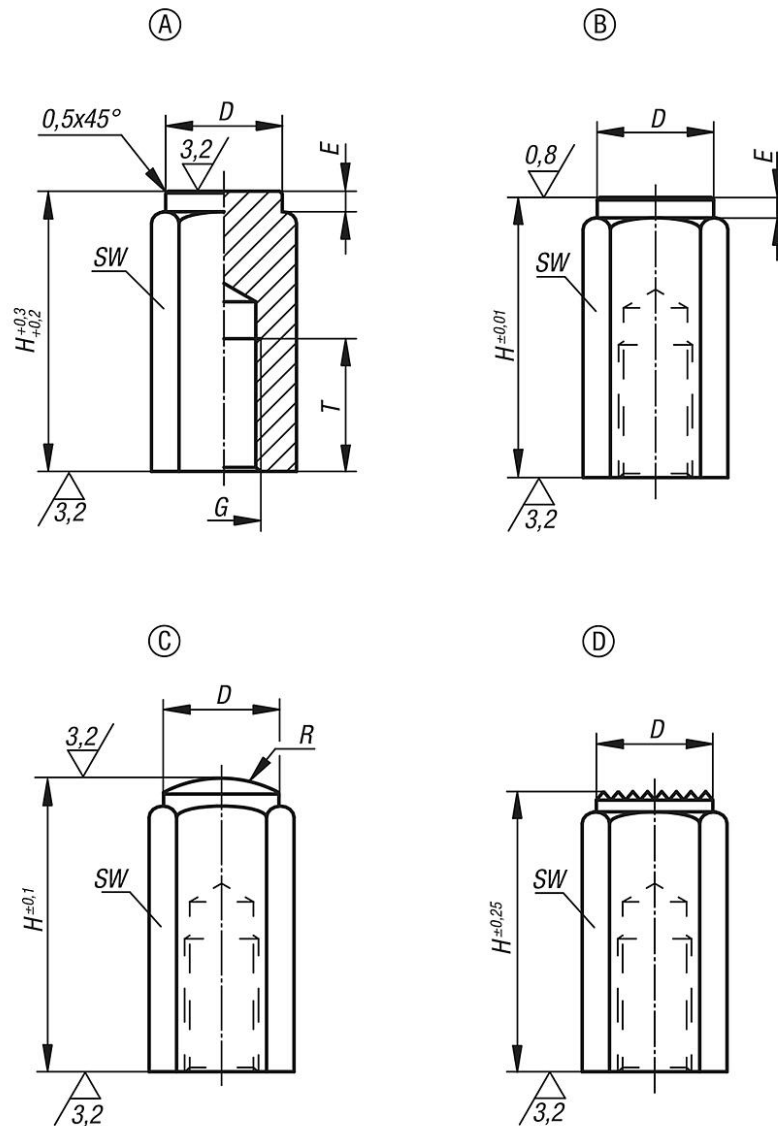

Overview of items

Fixture feet with internal thread

Order No.	Form	D	E	G	H	R	T	SW
B0185.106X20	A	9,5	2	M6	20	-	12	10
B0185.106X40	A	9,5	2	M6	40	-	12	10
B0185.110X32	A	16,5	3	M10	32	-	18	17
B0185.110X63	A	16,5	3	M10	63	-	18	17
B0185.112X32	A	18,5	3	M12	32	-	18	19
B0185.112X63	A	18,5	3	M12	63	-	18	19
B0185.116X50	A	23	4	M16	50	-	24	24
B0185.116X100	A	23	4	M16	100	-	24	24
B0185.206X20	B	9,5	2	M6	20	-	12	10
B0185.206X40	B	9,5	2	M6	40	-	12	10
B0185.210X32	B	16,5	3	M10	32	-	18	17
B0185.210X63	B	16,5	3	M10	63	-	18	17
B0185.212X32	B	18,5	3	M12	32	-	18	19
B0185.212X63	B	18,5	3	M12	63	-	18	19
B0185.216X50	B	23	4	M16	50	-	24	24

Fixture feet with internal thread

Overview of items

Order No.	Form	D	E	G	H	R	T	SW
B0185.216X100	B	23	4	M16	100	-	24	24
B0185.306X20	C	9,5	-	M6	20	15	12	10
B0185.306X40	C	9,5	-	M6	40	15	12	10
B0185.310X32	C	16,5	-	M10	32	30	18	17
B0185.310X63	C	16,5	-	M10	63	30	18	17
B0185.312X32	C	18,5	-	M12	32	35	18	19
B0185.312X63	C	18,5	-	M12	63	35	18	19
B0185.316X50	C	23	-	M16	50	40	24	24
B0185.316X100	C	23	-	M16	100	40	24	24
B0185.406X20	D	9,5	-	M6	20	-	12	10
B0185.406X40	D	9,5	-	M6	40	-	12	10
B0185.410X32	D	16,5	-	M10	32	-	18	17
B0185.410X63	D	16,5	-	M10	63	-	18	17
B0185.412X32	D	18,5	-	M12	32	-	18	19
B0185.412X63	D	18,5	-	M12	63	-	18	19
B0185.416X50	D	23	-	M16	50	-	24	24
B0185.416X100	D	23	-	M16	100	-	24	24