

# Rest pads

## Item description/product images



### Description

**Material:**  
Body high carbon steel.

**Version:**  
Body tempered and black oxidised.

**Note:**  
Rest pads are for supporting machined and non-machined parts. They can also be used as stops and thrust pads in fixtures and toolmaking. Studs or grub screws can be screwed and glued into the tapped hole D to make a rest pad with external thread.

**Drawing reference:**  
Form A: flat face  
Form B: ball end  
Form C: diamond grip

## Drawings

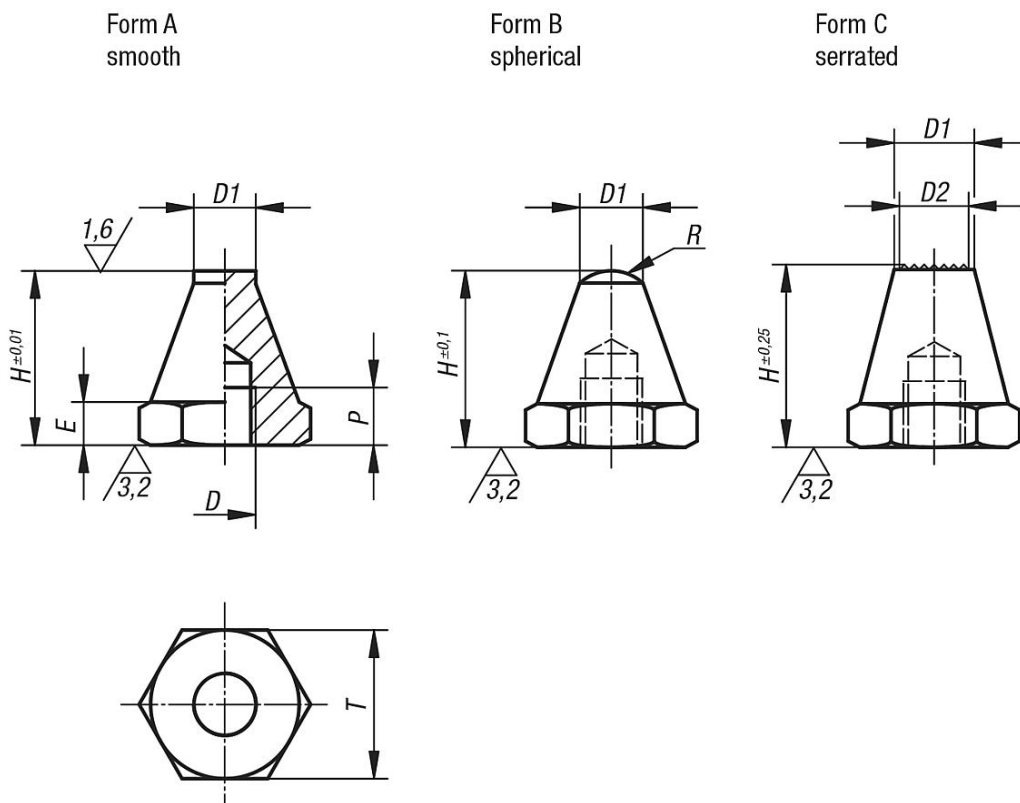

## Overview of items

### Rest pads

Order No.	Form	D	D1	D2	E	H	P	R	SW
B0186.106012	A	M6	6	-	3	12,5	4	-	11

## Rest pads

## Overview of items

Order No.	Form	D	D1	D2	E	H	P	R	SW
B0186.106025	A	M6	6	-	3	25	7	-	11
B0186.108015	A	M8	8	-	4	15	6	-	13
B0186.108030	A	M8	8	-	4	30	9	-	13
B0186.110020	A	M10	10	-	5	20	9	-	17
B0186.110040	A	M10	10	-	5	40	13	-	17
B0186.112025	A	M12	12	-	6	25	11	-	19
B0186.112050	A	M12	12	-	6	50	16	-	19
B0186.116030	A	M16	16	-	8	30	12	-	24
B0186.116060	A	M16	16	-	8	60	20	-	24
B0186.206012	B	M6	6	-	3	12,5	4	5	11
B0186.206025	B	M6	6	-	3	25	7	5	11
B0186.208015	B	M8	8	-	4	15	6	8,5	13
B0186.208030	B	M8	8	-	4	30	9	8,5	13
B0186.210020	B	M10	10	-	5	20	9	9	17
B0186.210040	B	M10	10	-	5	40	13	9	17
B0186.212025	B	M12	12	-	6	25	11	12,75	19
B0186.212050	B	M12	12	-	6	50	16	12,75	19
B0186.216030	B	M16	16	-	8	30	12	17	24
B0186.216060	B	M16	16	-	8	60	20	17	24
B0186.306012	C	M6	6	5	3	12,5	4	-	11
B0186.306025	C	M6	6	5	3	25	7	-	11
B0186.308015	C	M8	8	6	4	15	6	-	13
B0186.308030	C	M8	8	6	4	30	9	-	13
B0186.310020	C	M10	10	8	5	20	9	-	17
B0186.310040	C	M10	10	8	5	40	13	-	17
B0186.312025	C	M12	12	9,5	6	25	11	-	19
B0186.312050	C	M12	12	9,5	6	50	16	-	19
B0186.316030	C	M16	16	13	8	30	12	-	24
B0186.316060	C	M16	16	13	8	60	20	-	24