

Self-aligning pads self-righting

Item description/product images

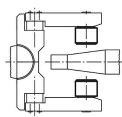

1. bring gripper into position



zero-point position of self-aligning pads

2. grip workpiece

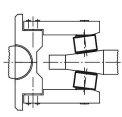

self-aligning pads adapt to workpiece contour

3. open gripper

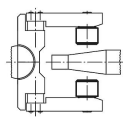

self-aligning pads swivel back automatically

Description

Material:

Carbon steel.

Version:

Hardened, black oxidised.

Note:

Self-aligning pads are used to support and clamp unmachined and machined workpieces.

They also serve as stops, supports and thrust pads in fixtures and toolmaking.

Advantages:

- The built-in O-ring prevents dirt and foreign particles from entering.
- The clamping surface swivels back automatically after clamping.
- High load rating and small size.

Drawing reference:

Form C: smooth face

Form F: serrated face

1) Hole for pin as a rotation lock

Self-aligning pads self-righting

Drawings

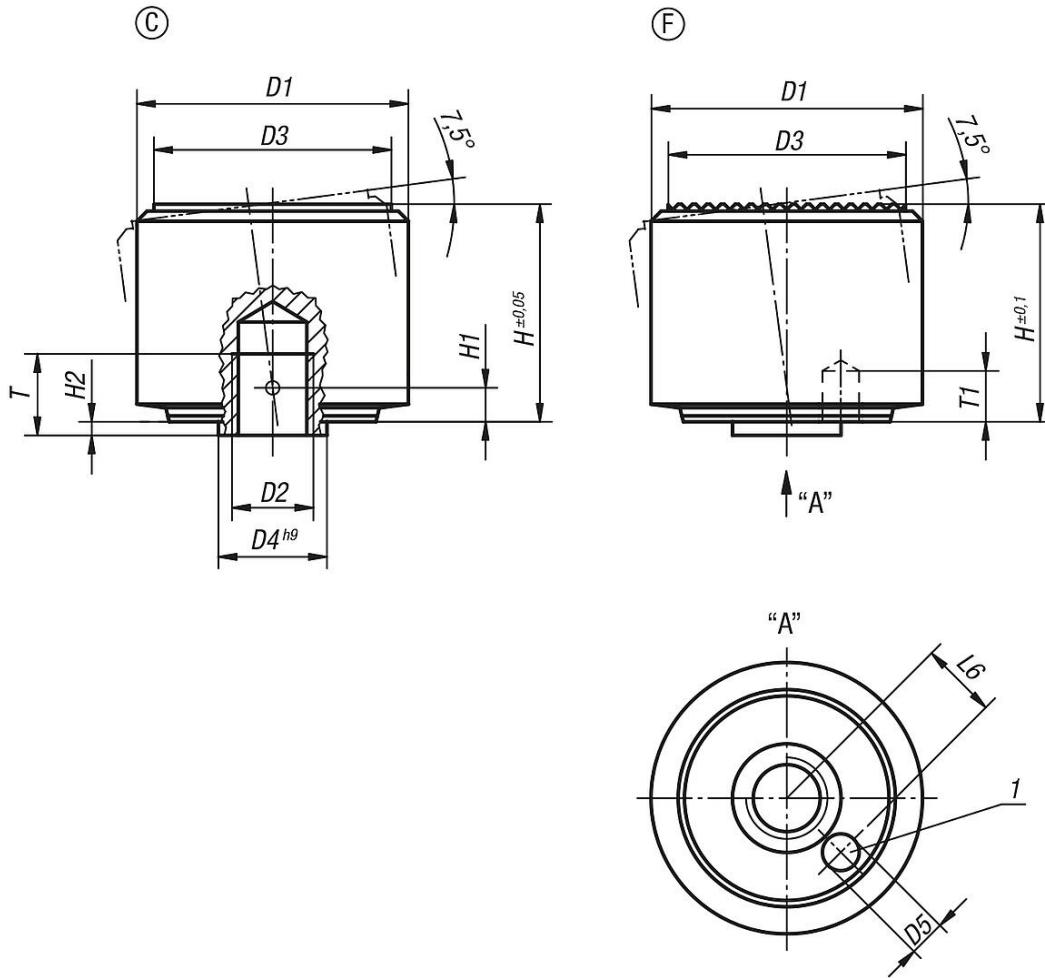

Overview of items

Order No.	Form	D1	D2	D3	D4	D5	H	H1	H2	T	T1	L6	Load rating max. kN (static load only)
B0151.105	C	18	M5	15	7	1,8	14	2,1	0,8	5	3	4,6	30
B0151.106	C	22	M6	18	8	2,8	16,5	2,5	1	6	4	5,6	50
B0151.108	C	28	M8	23	11	3,3	21,5	3,4	1,3	8	5	7,5	90
B0151.110	C	34	M10	29	13	4,4	27	4,2	1,6	10	6	9,2	140
B0151.112	C	40	M12	35	16	5,4	32	5	2	12	8	11,3	220
B0151.305	F	18	M5	15	7	1,8	14	2,1	0,8	5	3	4,6	30
B0151.306	F	22	M6	18	8	2,8	16,5	2,5	1	6	4	5,6	50
B0151.308	F	28	M8	23	11	3,3	21,5	3,4	1,3	8	5	7,5	90
B0151.310	F	34	M10	29	13	4,4	27	4,2	1,6	10	6	9,2	140
B0151.312	F	40	M12	35	16	5,4	32	5	2	12	8	11,3	220