

Locating cylinder with quick clamping system

Item description/product images



Description

Material:

Locating cylinder carbon steel.

Balls roller bearing steel.

Version:

Locating cylinder tempered, black oxidised.

Balls hardened, bright.

Note:

Locating cylinder with quick-clamp system for extra timesaving during setups.

Insert the locating cylinder into the receiving hole and press the button. The three balls are pushed out and position the components. By tightening the set screw a 1/4 turn using an hexagonal key, the components are positively and securely held.



Drawings

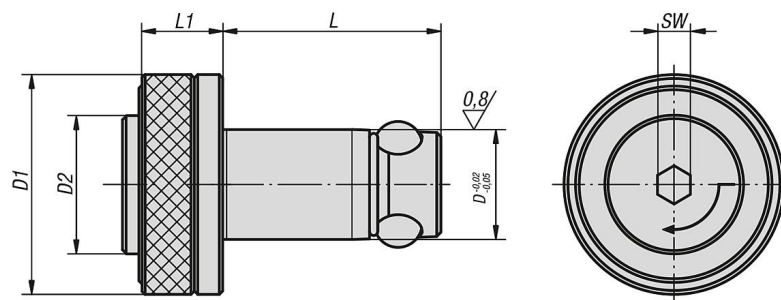

Overview of items

Locating cylinder with quick clamping system

Overview of items

Locating cylinder with quick clamping system

Order No.	Grid plate thickness $\pm 0,05$	D	D1	D2	L	L1	SW	Holding force F kN	Tightening torque max. Nm
B0211.120020	20	20	40	25	39,5	15	6	8	2
B0211.113013	13	13	25	16	27,6	12	4	4	1
B0211.113020	20	13	25	16	34,6	12	4	4	1
B0211.120025	25	20	40	25	44,5	15	6	8	2
B0211.116025	25	16	32	20	41,5	15	6	8	2
B0211.116020	20	16	32	20	36,5	15	6	8	2