

Elevating castors with integrated machine foot

Item description/product images



Description

Material:

Housing steel plate.

Roller break resistant polyamide 6, Shore 70D.

Machine foot steel.

Version:

Housing trivalent blue passivated.

Roller white.

Machine foot electro zinc-plated with grey rubber pads.

Note:

Elevating castor swivel version with integrated levelling machine foot. With sealed ball bearing in the swivel head. Wheel axle bolted. The ergonomic form of the non-swivelling actuating lever enables ease of operation. The short actuation travel with simultaneous long plunger stroke and very high lifting force enables heavy weights to be easily raised and safely fixated.

Drawing reference:

1) swivelling

Elevating castors with integrated machine foot

Drawings

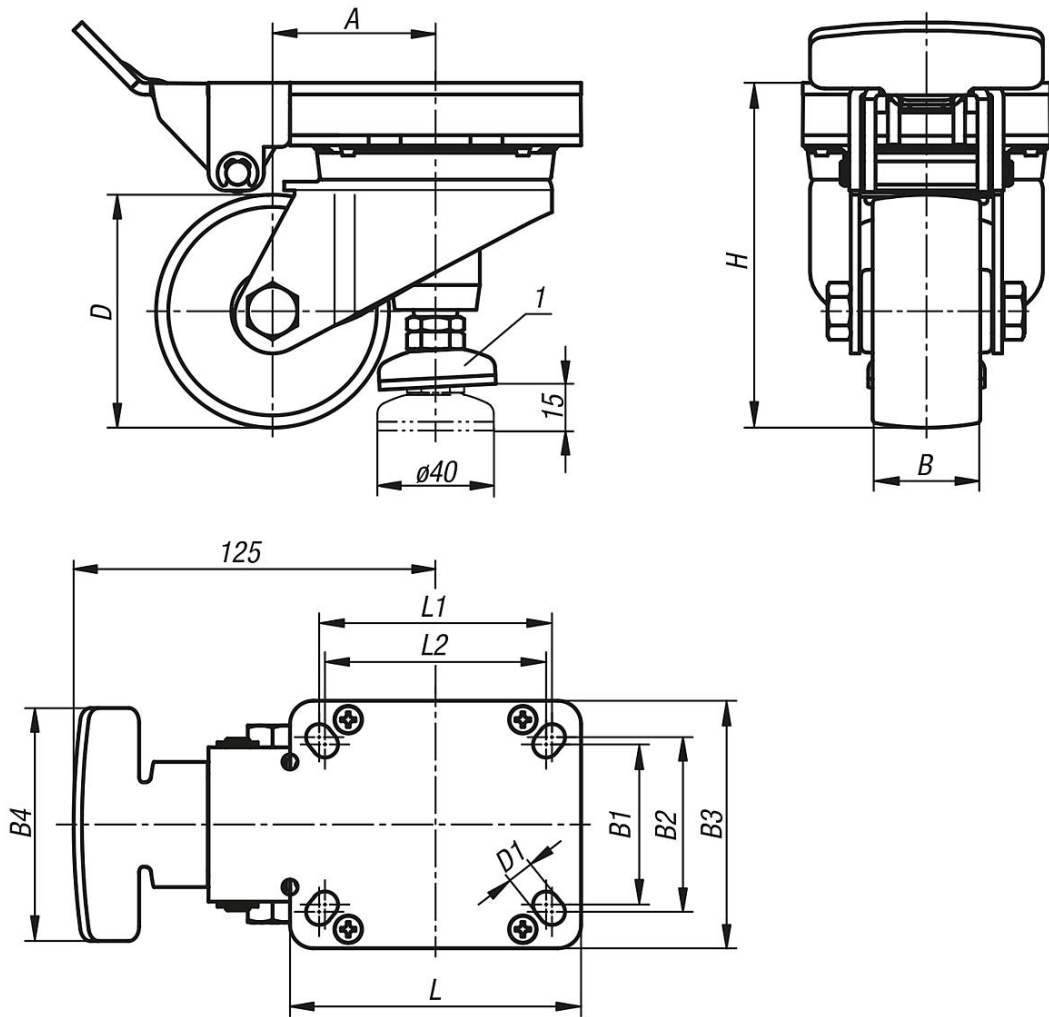

Overview of items

Elevating castors with integrated machine foot

Order No.	Version 1	Wheel bearing	D	A	B	B1	B2	B3	B4	D1	H	L	L1	L2	Permissible load kg
B0502.08037	with locking system	plain bearing	80	56	37	55	60	80	85	9	120	100	80	76	230
B0502.10037	with locking system	plain bearing	100	65	37	55	60	80	85	9	142	100	80	76	230