

Hook clamps with soft pad

Item description/product images



Description

Material:

Carbon steel.
Soft pad POM or polyurethane 99 Shore A.

Version:

Tempered and black oxidised.

Note:

The pressed in plastic inserts offer optimal damage protection for sensitive workpiece faces.

Drawings

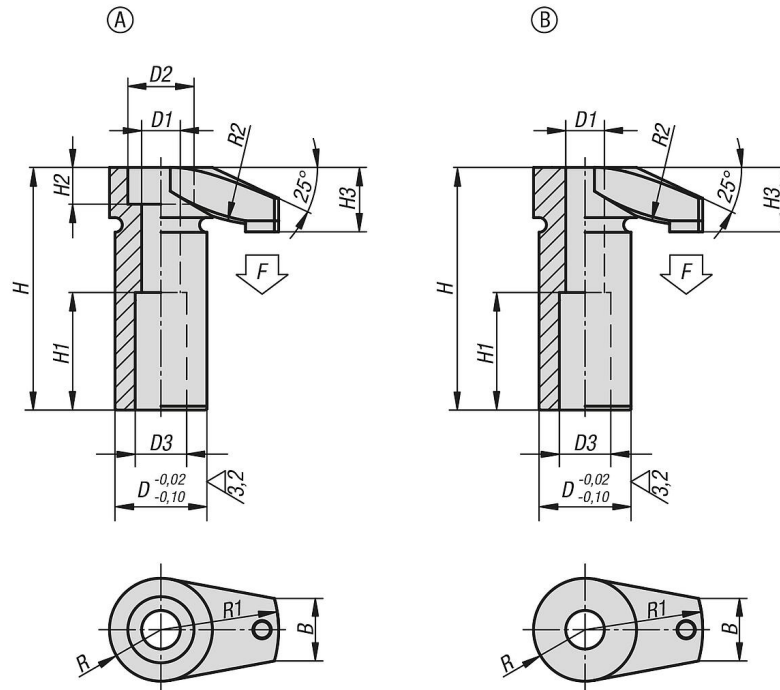

Overview of items

Hook clamps with soft pad

Order No.	Form	Component material	D	D1	D2	D3	H	H1	H2	H3	B	R	R1	R2	F max. kN
B0419.206	A	polyacetal	16	6,5	11	10	42	20	6	10,5	11	9	20	30	4,8
B0419.208	A	polyacetal	20	8,5	15	12	52	25	8	13,5	15	12	25	50	8,8
B0419.210	A	polyacetal	25	10,5	18	14	66	32	10	17,5	17	14	32	60	11,6
B0419.212	A	polyacetal	32	12,5	20	17	83	40	12	21	20	18	40	80	18,8
B0419.2106	B	polyacetal	16	6,5	-	10	41,5	20	-	10	11	9	20	30	4,8
B0419.2108	B	polyacetal	20	8,5	-	12	51,5	25	-	13	15	12	25	50	8,8
B0419.2110	B	polyacetal	25	10,5	-	14	65,5	32	-	17	17	14	32	60	11,6
B0419.2112	B	polyacetal	32	12,5	-	17	82,5	40	-	21	20	18	40	80	18,8
B0419.306	A	polyurethane	16	6,5	11	10	42	20	6	10,5	11	9	20	30	4,8
B0419.308	A	polyurethane	20	8,5	15	12	52	25	8	13,5	15	12	25	50	8,8
B0419.310	A	polyurethane	25	10,5	18	14	66	32	10	17,5	17	14	32	60	11,6
B0419.312	A	polyurethane	32	12,5	20	17	83	40	12	21	20	18	40	80	18,8

Hook clamps with soft pad

Overview of items

Order No.	Form	Component material	D	D1	D2	D3	H	H1	H2	H3	B	R	R1	R2	F max. kN
B0419.3106	B	polyurethane	16	6,5	-	10	41,5	20	-	10	11	9	20	30	4,8
B0419.3108	B	polyurethane	20	8,5	-	12	51,5	25	-	13	15	12	25	50	8,8
B0419.3110	B	polyurethane	25	10,5	-	14	65,5	32	-	17	17	14	32	60	11,6
B0419.3112	B	polyurethane	32	12,5	-	17	82,5	40	-	21	20	18	40	80	18,8