

## Side clamps, Form C

### Item description/product images



### Description

**Material:**

Steel.

**Version:**

Case-hardened and black oxidised.

**Note:**

This is a quick-action side clamp where workpieces are clamped by rotating a cam wheel which exerts pressure on the swivel jaw, simultaneously producing a positive down force.

Using the stop screw and centring bush (see diagram), the side clamp can be mounted and positioned on a modular grid system.

The versions B0403.006010, B0403.006015, B0403.006030 and B0403.006035 have 2 round carbide inserts.

**Clamping force:**

B0403.006... = 3800 N

B0403.010... = 7200 N

### Drawings

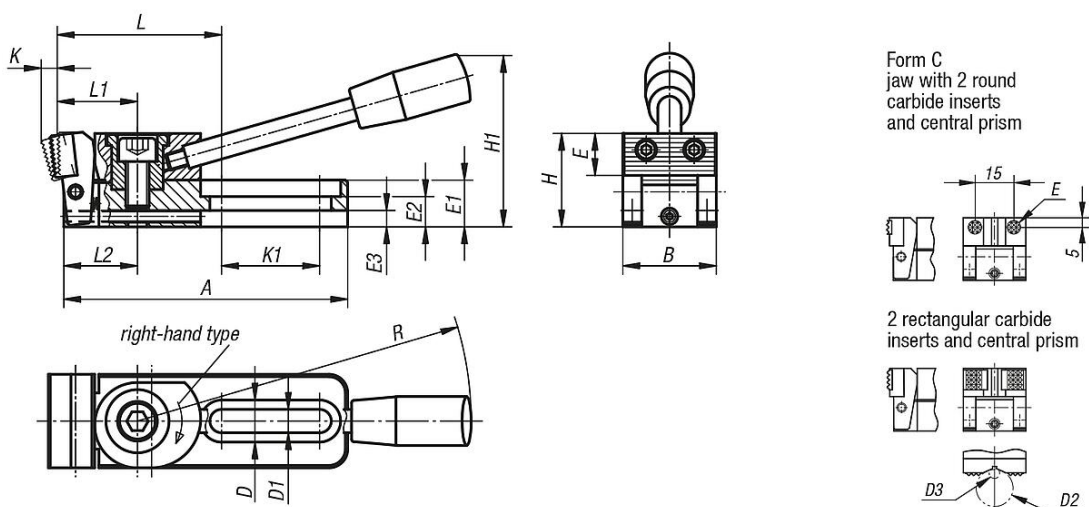

### Overview of items

Order No.	Form	Version 1	A	B	D	D1	D2 max.	D3 min.	E	E1	E2	E3	H	H1	K	K1	L	L1	L2	R	F=Retaining force N
B0403.006015	C	right	78	25	12	6,2	9,5	2,5	ø8	12	8	4	24	45	3,5	26	46,5	22	20	110	3800
B0403.010015	C	right	121,5	40	18	10,2	27	4,5	12,7	20	13	7	39	74	5,5	42	73	35	31,5	143	7200
B0403.006035	C	left	78	25	12	6,2	9,5	2,5	ø8	12	8	4	24	45	3,5	26	46,5	22	20	110	3800
B0403.010035	C	left	121,5	40	18	10,2	27	4,5	12,7	20	13	7	39	74	5,5	42	73	35	31,5	143	7200

## Side clamps, Form C

Overview of items

---