

Side clamps, Form A

Item description/product images



Description

Material:
Steel.

Version:
Case-hardened and black oxidised.

Note:
This is a quick-action side clamp where workpieces are clamped by rotating a cam wheel which exerts pressure on the swivel jaw, simultaneously producing a positive down force.
Using the centring bush (see diagram), the side clamp can be mounted and positioned on a modular grid system.

The versions B0404.006010, B0404.006015, B0404.006030 and B0404.006035 have 2 round carbide inserts.

Clamping force:
B0404.006... = 3800 N
B0404.010... = 7200 N

Drawings

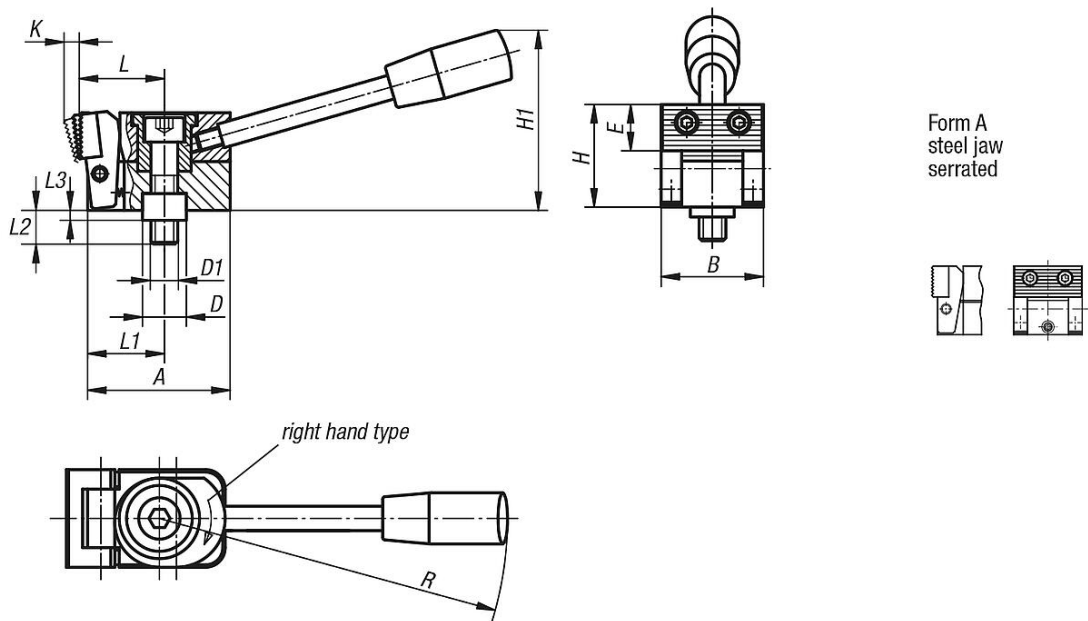

Form A
steel jaw
serrated

Overview of items

Order No.	Form	Version 1	A	B	D	D1	E	H	H1	K	L	L1	L2	L3	R	F N
B0404.006005	A	right	38,5	25	12	M6	11	25	45	4	22	20	17	4	110	3800
B0404.010005	A	right	58,5	40	18	M10	18	40	74	6	35	31,5	27	6	143	7200
B0404.006025	A	left	38,5	25	12	M6	11	25	45	4	22	20	17	4	110	3800
B0404.010025	A	left	58,5	40	18	M10	18	40	74	6	35	31,5	27	6	143	7200

Side clamps, Form A

Overview of items
