

Fixed castors

Item description/product images



Description

Material:

Housing thick steel plate.
Tyres steel-wire reinforced elastic solid rubber.
Wheel body welded steel.

Version:

Pressed housing; reinforced fork, top plate and swivel head bolt; wheels with precision ball bearing

Note:

These castors are particularly impact and shock proof and assure a high service life. Wheel axle bolted.

Drawings

fixed castor

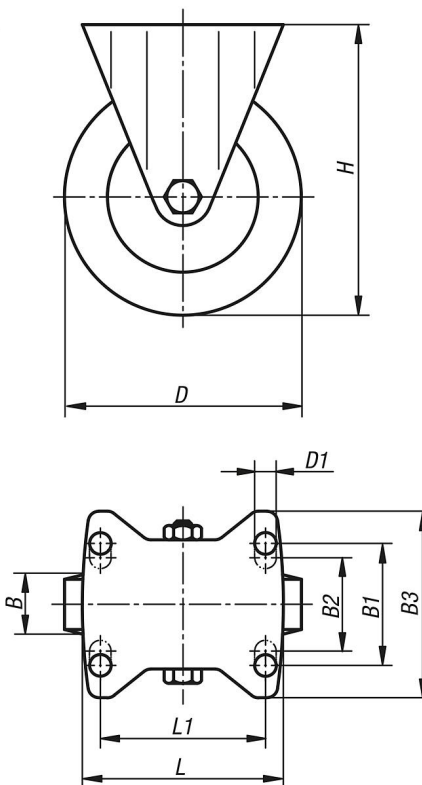

Overview of items

Order No.	Item	Version 1	Wheel bearing	B	B1	B2	B3	D	D1	H	L	L1	Permissible load kg
B0484.100401	Fixed castor	without locking system	ball bearing	40	60	-	85	100	9	140	100	80	180
B0484.125501	Fixed castor	without locking system	ball bearing	50	80	75	110	125	11	170	140	105	280
B0484.160501	Fixed castor	without locking system	ball bearing	50	80	75	110	160	11	202	140	105	400
B0484.200501	Fixed castor	without locking system	ball bearing	50	80	75	110	200	11	245	140	105	500
B0484.250601	Fixed castor	without locking system	ball bearing	60	80	75	110	250	11	295	140	105	700

Fixed castors

Overview of items
