

Swivel castors with "stop-top"

Item description/product images



Description

Material:

Housing thick steel plate.

Tyres steel-wire reinforced elastic solid rubber.

Wheel body welded steel.

Version:

Housing pressed. Reinforced forks, base plates and swivel head bolts. Wheels with precision ball bearing.

Note:

These castors are particularly impact and shock proof and assure a high service life. Wheel axle bolted.

Drawings

swivel castor
with "stop-top"

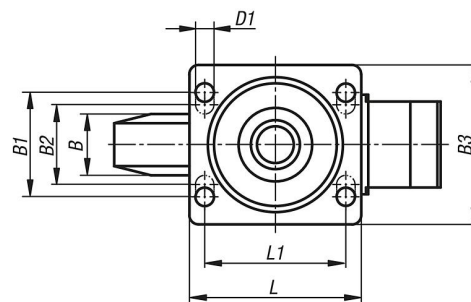
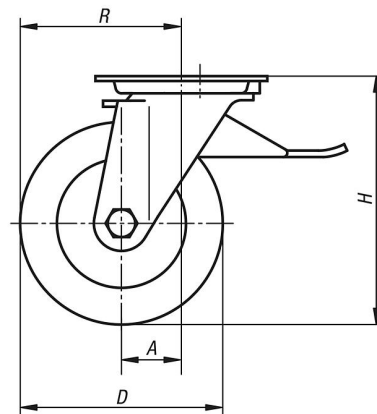

swivel head bearing

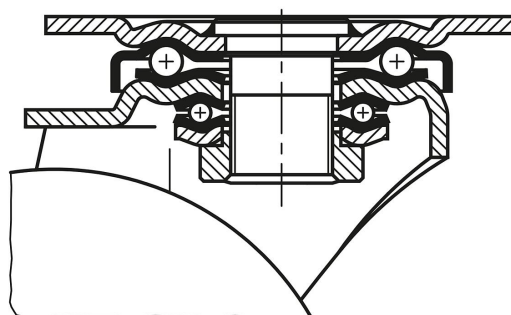

Swivel castors with "stop-top"

Overview of items

Order No.	Item	Version 1	Wheel bearing	A	B	B1	B2	B3	D	D1	H	L	L1	R	Permissible load kg
B0484.100402	Swivel castor	with stop-top locking system	ball bearing	45	40	60	-	85	100	9	140	100	80	95	180
B0484.125502	Swivel castor	with stop-top locking system	ball bearing	55	50	80	75	110	125	11	170	140	105	117,5	280
B0484.160502	Swivel castor	with stop-top locking system	ball bearing	65	50	80	75	110	160	11	202	140	105	145	400
B0484.200502	Swivel castor	with stop-top locking system	ball bearing	70	50	80	75	110	200	11	245	140	105	170	500
B0484.250602	Swivel castor	with stop-top locking system	ball bearing	82	60	80	75	110	250	11	295	140	105	207	700