

Swivel castors with "stop-fix"

Item description/product images



Description

Material:

Housing steel plate.

Wheel body PA 6 with abrasion-resistant polyurethane tread.

Version:

Housing press formed.

Double ball bearing with ball shield in the castor head.

Plain bearing in the wheels.

Note:

The wheels are unbreakable, maintenance-free and non-corroding. Wheel axle bolted. Tread non-marking.

Drawings

swivel castor with "stop-fix"

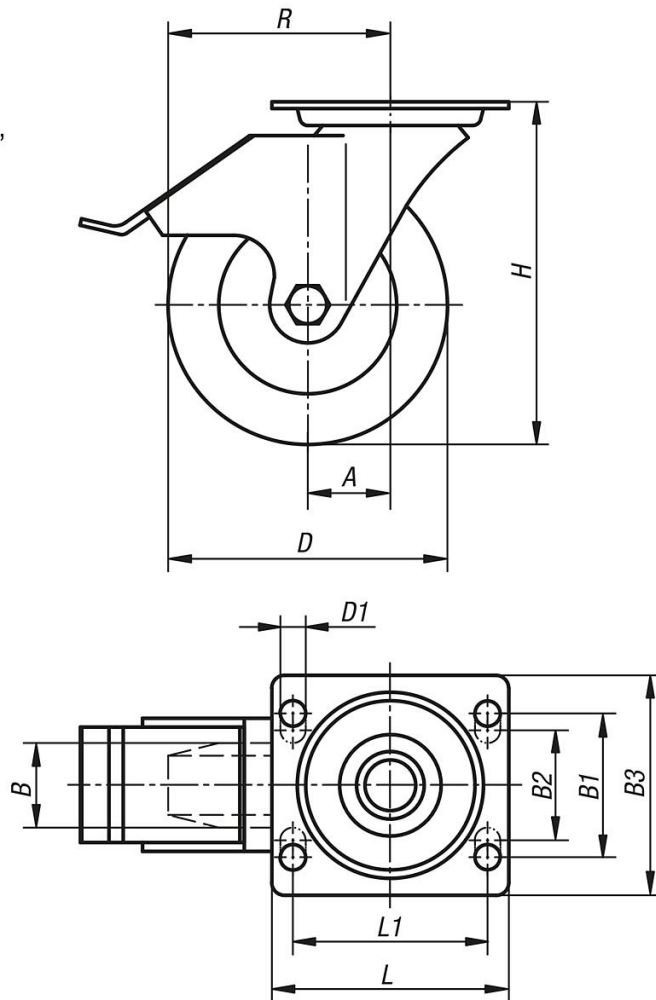

Swivel castors with "stop-fix"

Drawings

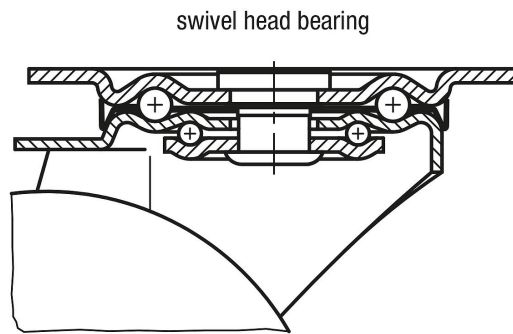

Overview of items

Order No.	Item	Version 1	Wheel bearing	A	B	B1	B2	B3	D	D1	H	L	L1	R	Permissible load kg
B0485.100352	Swivel castor	with stop-fix locking system	plain bearing	36	35	60	-	85	100	9	125	100	80	86	200
B0485.125352	Swivel castor	with stop-fix locking system	plain bearing	40	40	60	-	85	125	9	150	100	80	102,5	200
B0485.150402	Swivel castor	with stop-fix locking system	plain bearing	60	45	80	75	110	150	11	190	140	105	135	400
B0485.200502	Swivel castor	with stop-fix locking system	plain bearing	65	50	80	75	110	200	11	235	140	105	165	400