

Swivel castors with stop top

Item description/product images



Description

Material:

Housing thick steel plate.

Wheels PA 6.

Version:

Housing press formed.

Swivel castor housing with strong fork and base plate, very robust centre pin bolted and secured. The swivel head is additionally reinforced with specially formed and hardened bearing shells.

Plain bearings in the wheels.

Note:

Wheel axle bolted. The wheels are particularly shock and impact proof and have high abrasion resistance.

Drawings

swivel castor
with "stop-top"

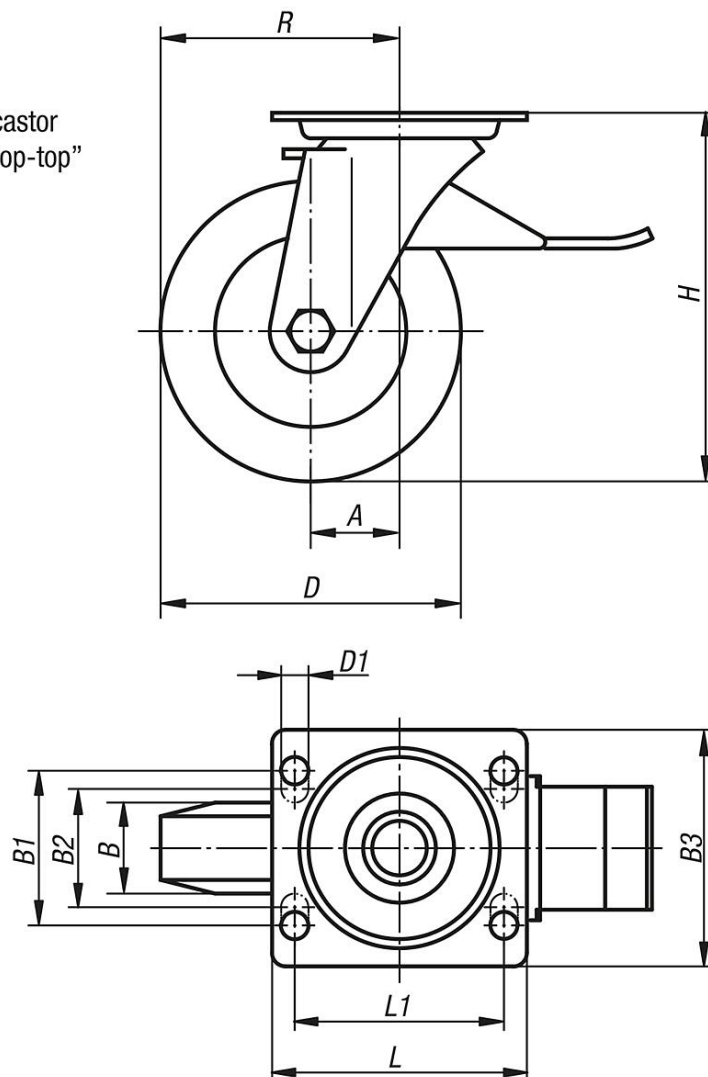

Swivel castors with stop top

Drawings

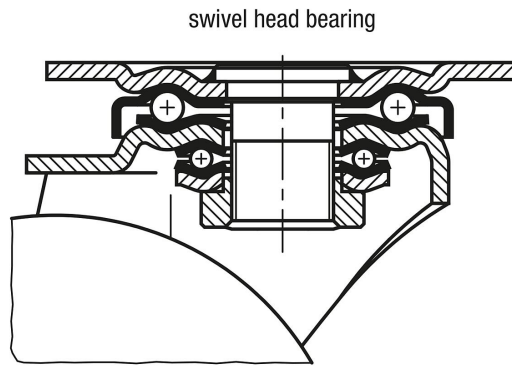

Overview of items

Order No.	Item	Version 1	Wheel bearing	A	B	B1	B2	B3	D	D1	H	L	L1	R	Permissible load kg
B0490.100372	Swivel castor	with stop-top locking system	plain bearing	45	37	60	-	85	100	9	140	100	80	95	280
B0490.125402	Swivel castor	with stop-top locking system	plain bearing	45	40	60	-	85	125	9	165	100	80	107,5	300
B0490.150502	Swivel castor	with stop-top locking system	plain bearing	65	50	80	75	110	150	11	197	140	105	140	400
B0490.200502	Swivel castor	with stop-top locking system	plain bearing	70	50	80	75	110	200	11	245	140	105	170	600