

Levelling feet in Hygienic DESIGN

Item description/product images



by MARTIN

Levelling Components

Description

Material:

Foot plate and threaded spindle stainless steel 1.4301.
Rubber base (NBR) Shore 85 +/-5, FDA tested.
Rubber seal, silicone, FDA tested.

Version:

Foot plate, high-gloss polished.
Threaded spindle, bright.
Rubber base, black.
Rubber seal, blue.

Note:

Certified according to 3-A Sanitary Standard.

The high surface quality, the double sealing of the thread and the special seal on the machine foot's spindle joint prevent dirt from sticking and reduce cleaning times to a minimum.

The machine foot is supplied with the 3-A logo.

Application:

The machine foot is particularly suitable for machines, plants and appliances in the foodstuff industry, breweries, dairies, beverage and pharmaceutical industries.

Accessory:

Thread cover B0522.

Drawing reference:

1) Adjustment range

Levelling feet in Hygienic DESIGN

Drawings

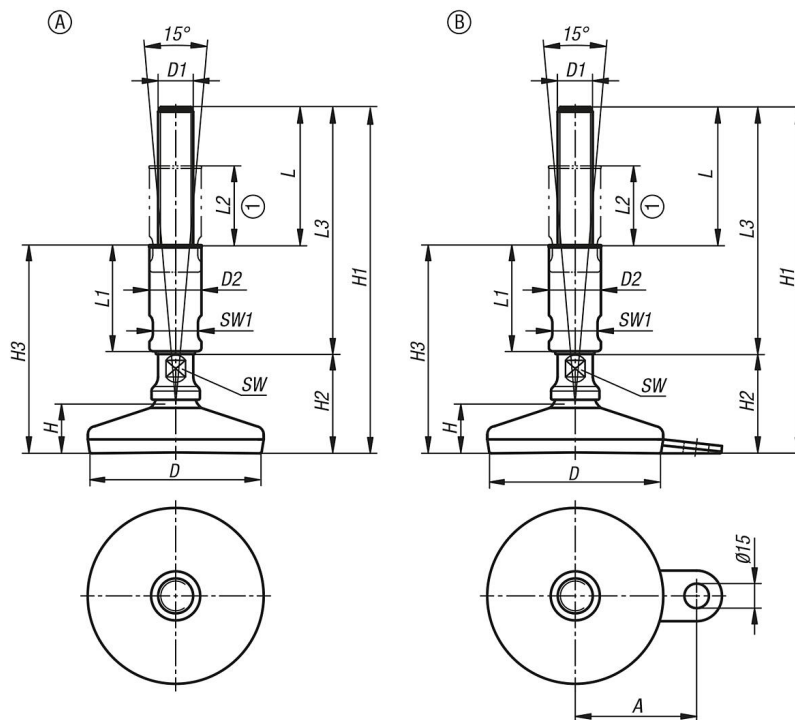

Overview of items

Levelling feet in Hygienic DESIGN

Order No.	Form	A	D	D1	D2	H	H1	H2	H3	L	L1	L2	L3	SW	SW1	Load rating max. kN (static load only)
B0374.106012X140	A	-	60	M12	24	23	191	51	112	79	60	45	140	13	20	10
B0374.106012X190	A	-	60	M12	24	23	241	51	137	104	85	70	190	13	20	10
B0374.106016X140	A	-	60	M16	24	23	191	51	112	79	60	45	140	13	20	10
B0374.106016X190	A	-	60	M16	24	23	241	51	137	104	85	70	190	13	20	10
B0374.108016X140	A	-	80	M16	24	25	193	53	114	79	60	45	140	13	20	20
B0374.108016X190	A	-	80	M16	24	25	243	53	139	104	85	70	190	13	20	20
B0374.108020X140	A	-	80	M20	30	25	193	53	114	79	60	45	140	17	26	20
B0374.108020X190	A	-	80	M20	30	25	243	53	139	104	85	70	190	17	26	20
B0374.108024X140	A	-	80	M24	35	25	193	53	114	79	60	45	140	20	30	20
B0374.108024X190	A	-	80	M24	35	25	243	53	139	104	85	70	190	20	30	20
B0374.110016X140	A	-	100	M16	24	28	196	56	117	79	60	45	140	13	20	25
B0374.110016X190	A	-	100	M16	24	28	246	56	142	104	85	70	190	13	20	25
B0374.110020X140	A	-	100	M20	30	28	196	56	117	79	60	45	140	17	26	25
B0374.110020X190	A	-	100	M20	30	28	246	56	142	104	85	70	190	17	26	25
B0374.110024X140	A	-	100	M24	35	28	196	56	117	79	60	45	140	20	30	25
B0374.110024X190	A	-	100	M24	35	28	246	56	142	104	85	70	190	20	30	25
B0374.112016X140	A	-	120	M16	24	32	200	60	121	79	60	45	140	13	20	30
B0374.112016X190	A	-	120	M16	24	32	250	60	146	104	85	70	190	13	20	30
B0374.112020X140	A	-	120	M20	30	32	200	60	121	79	60	45	140	17	26	30
B0374.112020X190	A	-	120	M20	30	32	250	60	146	104	85	70	190	17	26	30
B0374.112024X140	A	-	120	M24	35	32	200	60	121	79	60	45	140	20	30	30
B0374.112024X190	A	-	120	M24	35	32	250	60	146	104	85	70	190	20	30	30
B0374.206012X140	B	45	60	M12	24	23	191	51	112	79	60	45	140	13	20	10
B0374.206012X190	B	45	60	M12	24	23	241	51	137	104	85	70	190	13	20	10
B0374.206016X140	B	45	60	M16	24	23	191	51	112	79	60	45	140	13	20	10
B0374.206016X190	B	45	60	M16	24	23	241	51	137	104	85	70	190	13	20	10
B0374.208016X140	B	54	80	M16	24	25	193	53	114	79	60	45	140	13	20	20
B0374.208016X190	B	54	80	M16	24	25	243	53	139	104	85	70	190	13	20	20

Levelling feet in Hygienic DESIGN

Overview of items

Order No.	Form	A	D	D1	D2	H	H1	H2	H3	L	L1	L2	L3	SW	SW1	Load rating max. kN (static load only)
B0374.208020X140	B	54	80	M20	30	25	193	53	114	79	60	45	140	17	26	20
B0374.208020X190	B	54	80	M20	30	25	243	53	139	104	85	70	190	17	26	20
B0374.208024X140	B	54	80	M24	35	25	193	53	114	79	60	45	140	20	30	20
B0374.208024X190	B	54	80	M24	35	25	243	53	139	104	85	70	190	20	30	20
B0374.210016X140	B	69	100	M16	24	28	196	56	117	79	60	45	140	13	20	25
B0374.210016X190	B	69	100	M16	24	28	246	56	142	104	85	70	190	13	20	25
B0374.210020X140	B	69	100	M20	30	28	196	56	117	79	60	45	140	17	26	25
B0374.210020X190	B	69	100	M20	30	28	246	56	142	104	85	70	190	17	26	25
B0374.210024X140	B	69	100	M24	35	28	196	56	117	79	60	45	140	20	30	25
B0374.210024X190	B	69	100	M24	35	28	246	56	142	104	85	70	190	20	30	25